

23-30-20-P1

EFFECTIVITY:  
SEE T.O.C.

MUSIC ANNOUNCER  
(WITHOUT SB 737-23-0001)

DRAWING NO.: 0340-23-0003A  
PAGE DATE: MAY 19, 2010  
DCN: 1  
CHANGE: 24

23-30-20  
PAGE 1

23-30-20  
PAGE 1

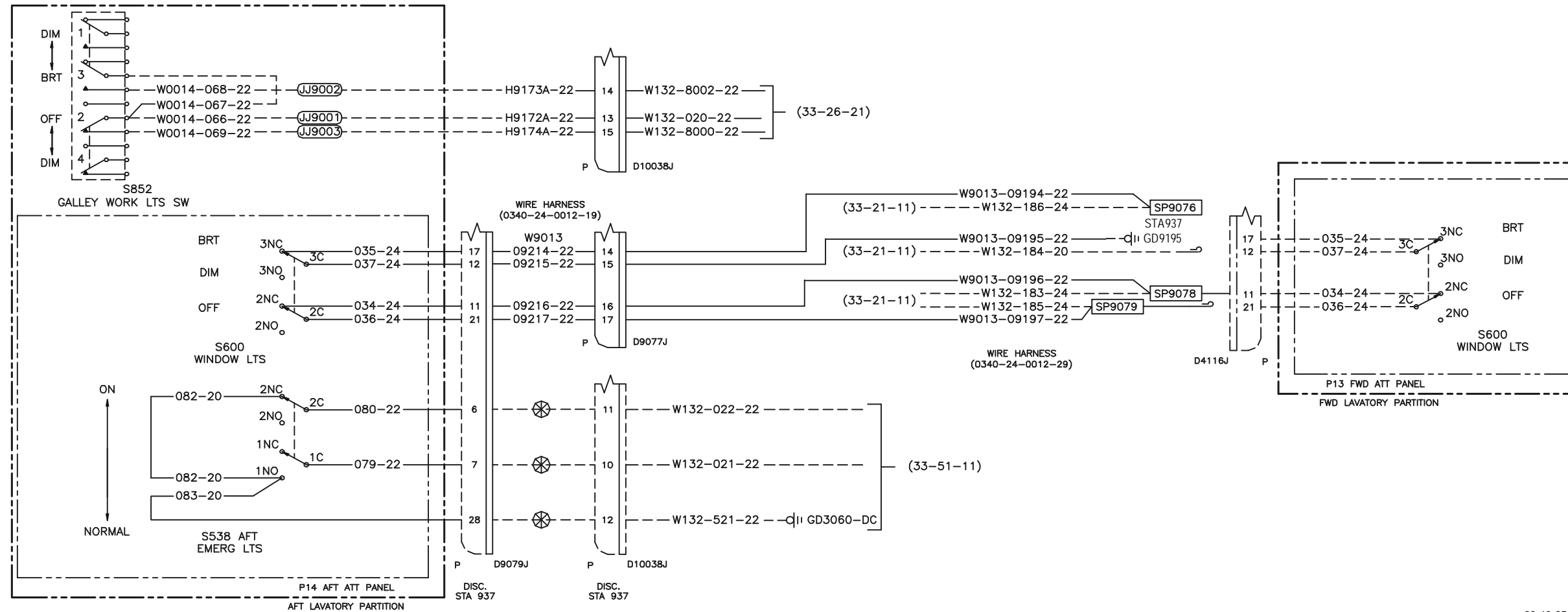

23-40-25-P1-S3

EFFECTIVITY:  
SEE T.O.C.

ATTENDANT PANEL EXTENSION  
(WITHOUT SB 737-23-0001)

DRAWING NO.: 0340-24-0013D  
PAGE DATE: MAY 19, 2010  
DCN:  
CHANGE: 24

23-40-25  
PAGE 1  
SHEET 3

23-40-25  
PAGE 1  
SHEET 3

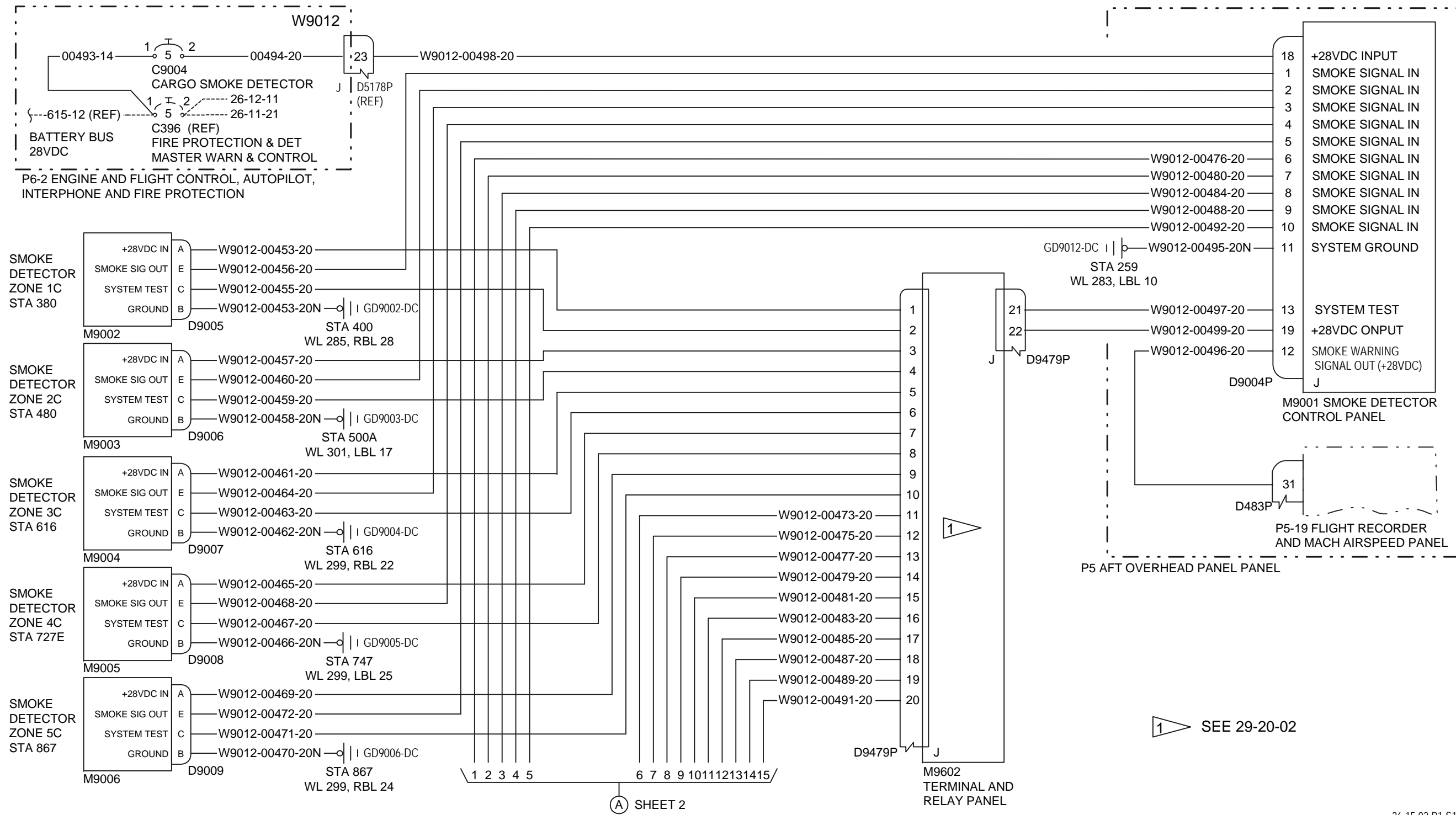

26-15-02-P1-S1

(A) SHEET 1

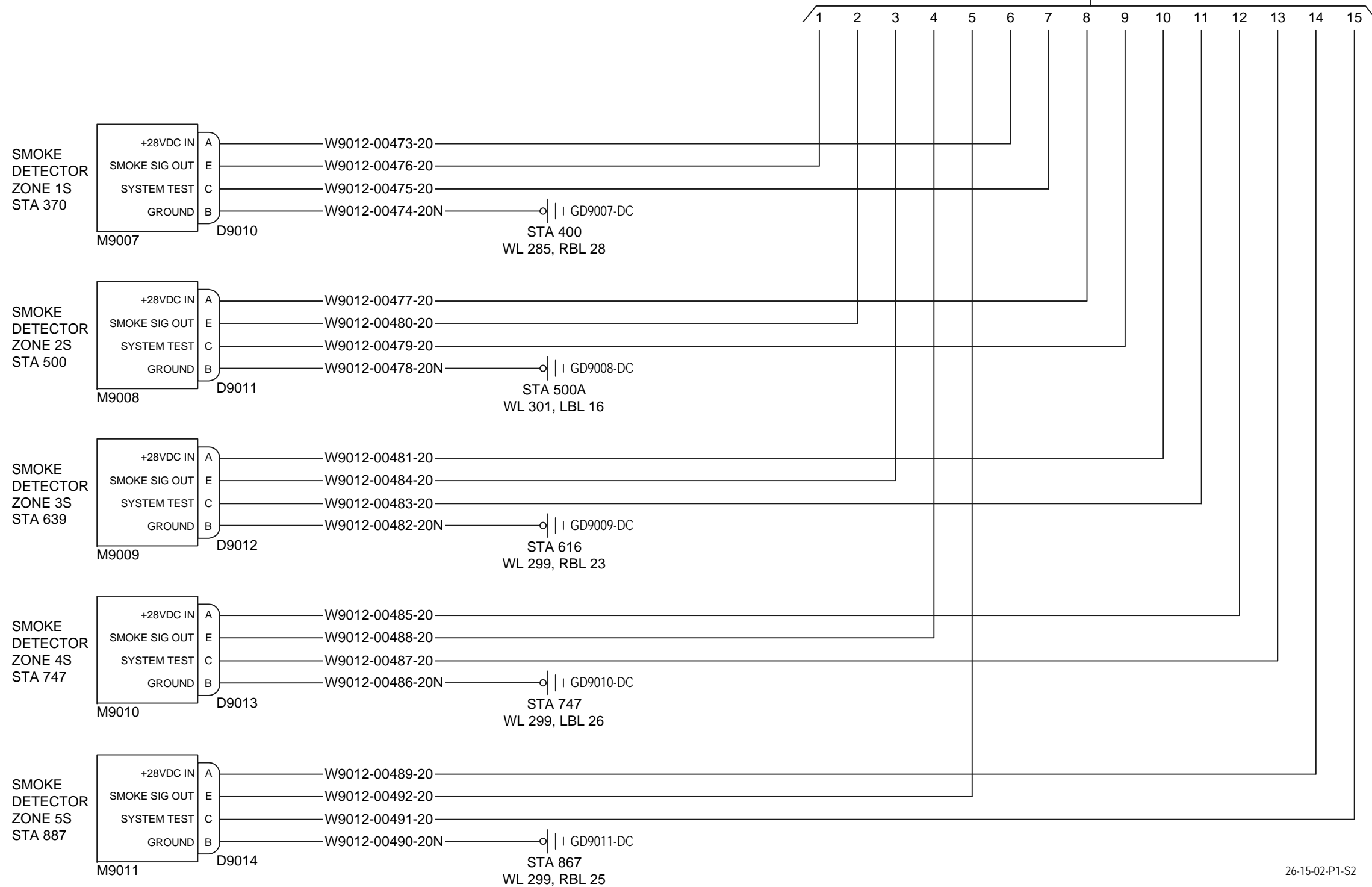

26-15-02-P1-S2

EFFECTIVITY:  
SEE T.O.C.

SMOKE DETECTOR SYSTEM

DRAWING NO.: 0301-24-0042  
PAGE DATE: MAY 19, 2010  
DCN: 1  
CHANGE: 24

26-15-02  
PAGE 1  
SHEET 2

26-15-02  
PAGE 1  
SHEET 2



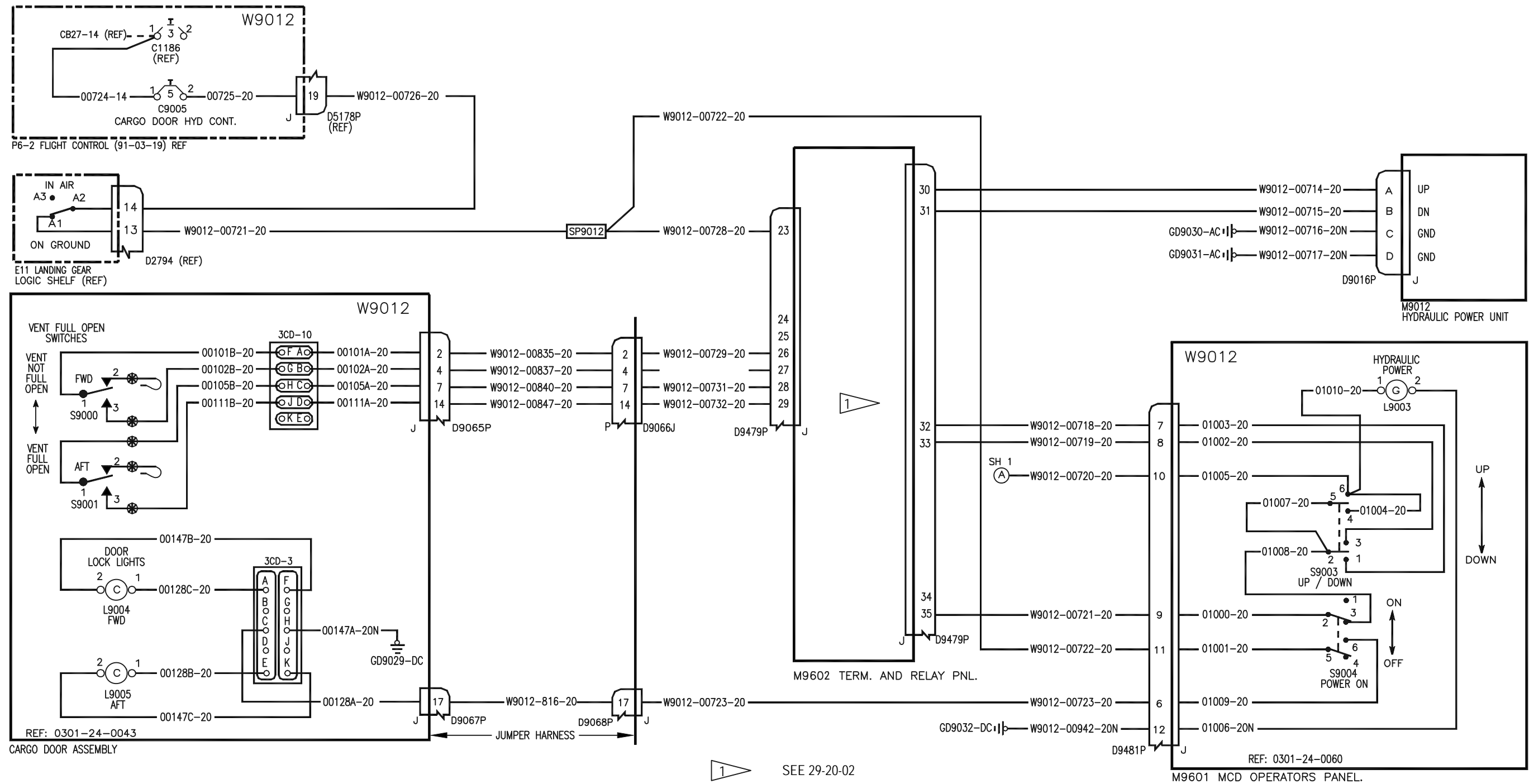

1 SEE 29-20-02

29-20-01-P1

EFFECTIVITY:  
SEE T.O.C.

CARGO DOOR HYDRAULIC POWER SYSTEM

DRAWING NO.: 0301-24-0044  
PAGE DATE: MAY 19, 2010  
DCN:  
CHANGE: 24

29-20-01  
PAGE 1

29-20-01  
PAGE 1

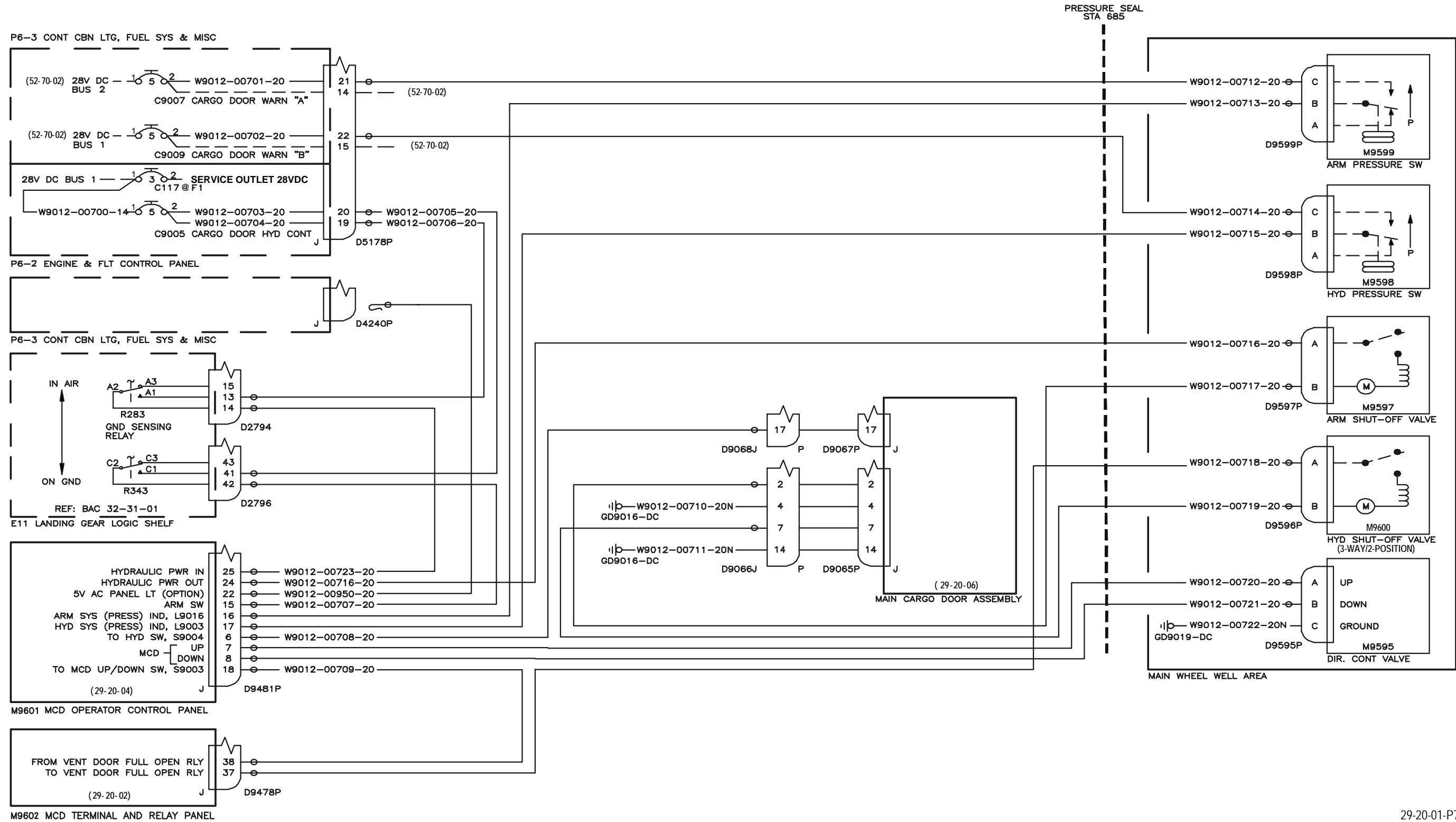

29-20-01-P7

EFFECTIVITY:  
SEE T.O.C.

**CARGO DOOR HYDRAULIC POWER SYSTEM**

DRAWING NO.: 0301-24-0049  
PAGE DATE: MAY 19, 2010  
DCN: 2  
CHANGE: 24

**29-20-01**  
PAGE 7

**29-20-01**  
PAGE 7

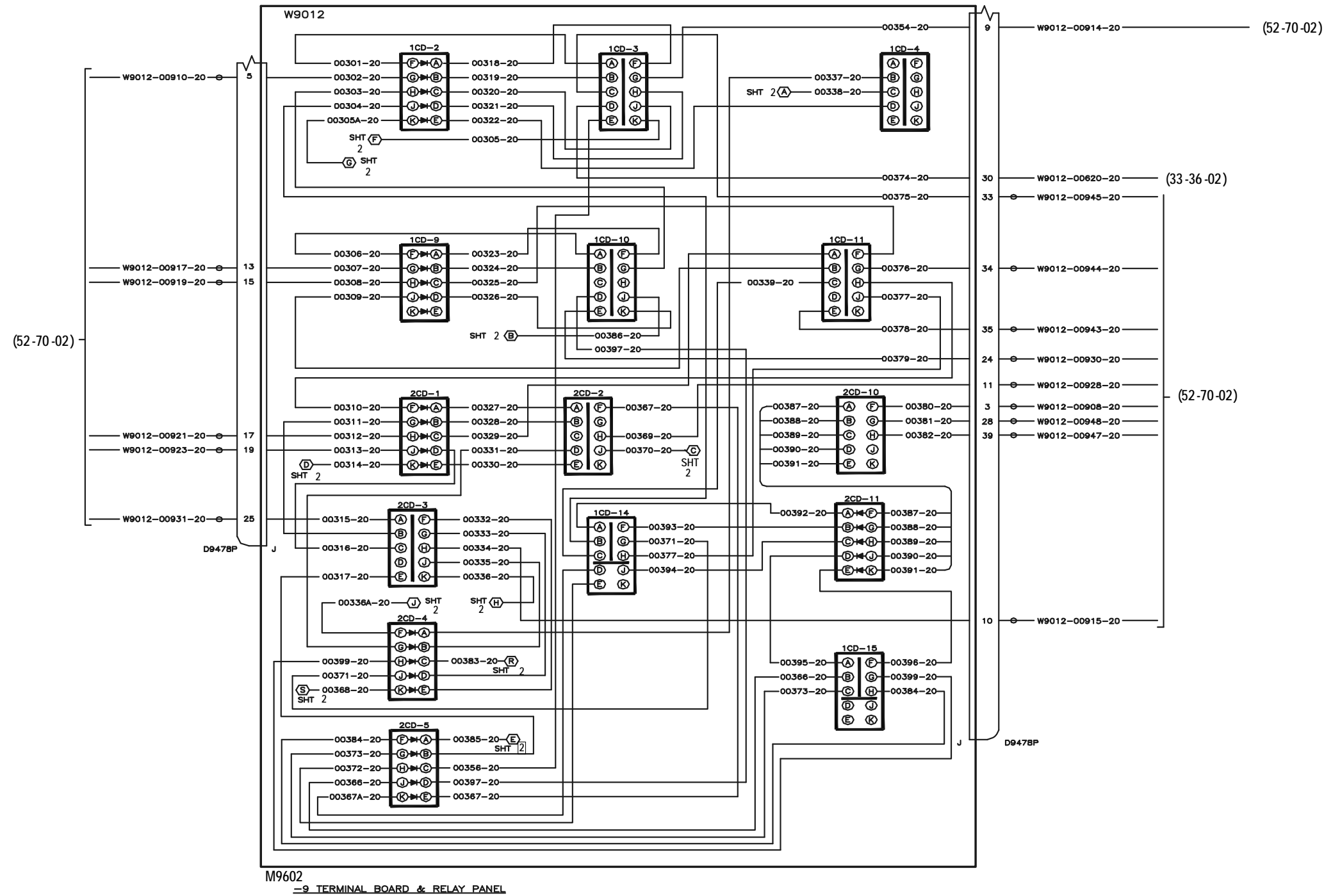

29-20-02-P2-S1

EFFECTIVITY:  
SEE T.O.C.

CARGO DOOR TERMINAL AND  
RELAY PANEL

DRAWING NO.: 0340-24-0004B  
PAGE DATE: MAY 19, 2010  
DCN: 1  
CHANGE: 24

29-20-02  
PAGE 2  
SHEET 1

29-20-02  
PAGE 2  
SHEET 1

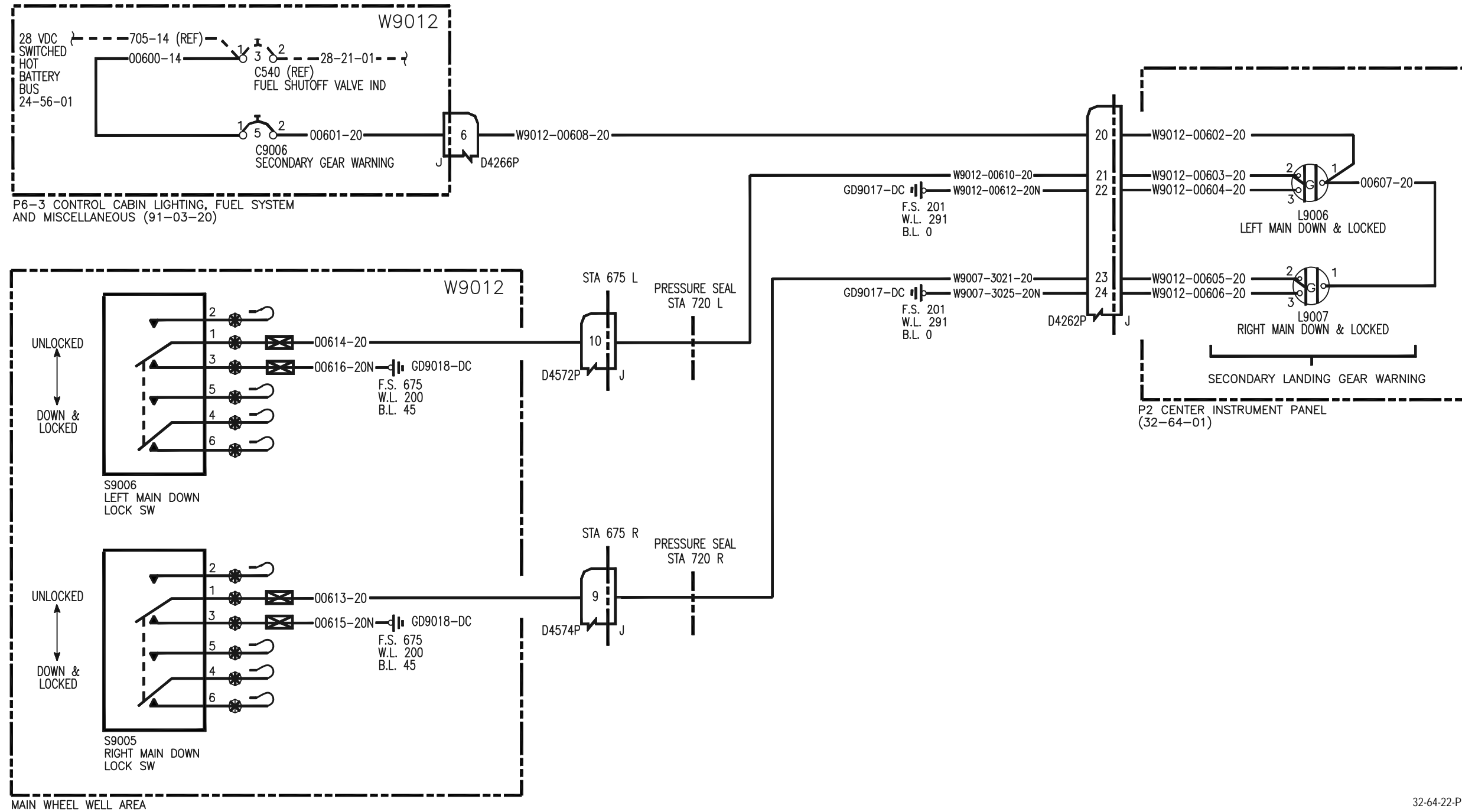

32-64-22-P1

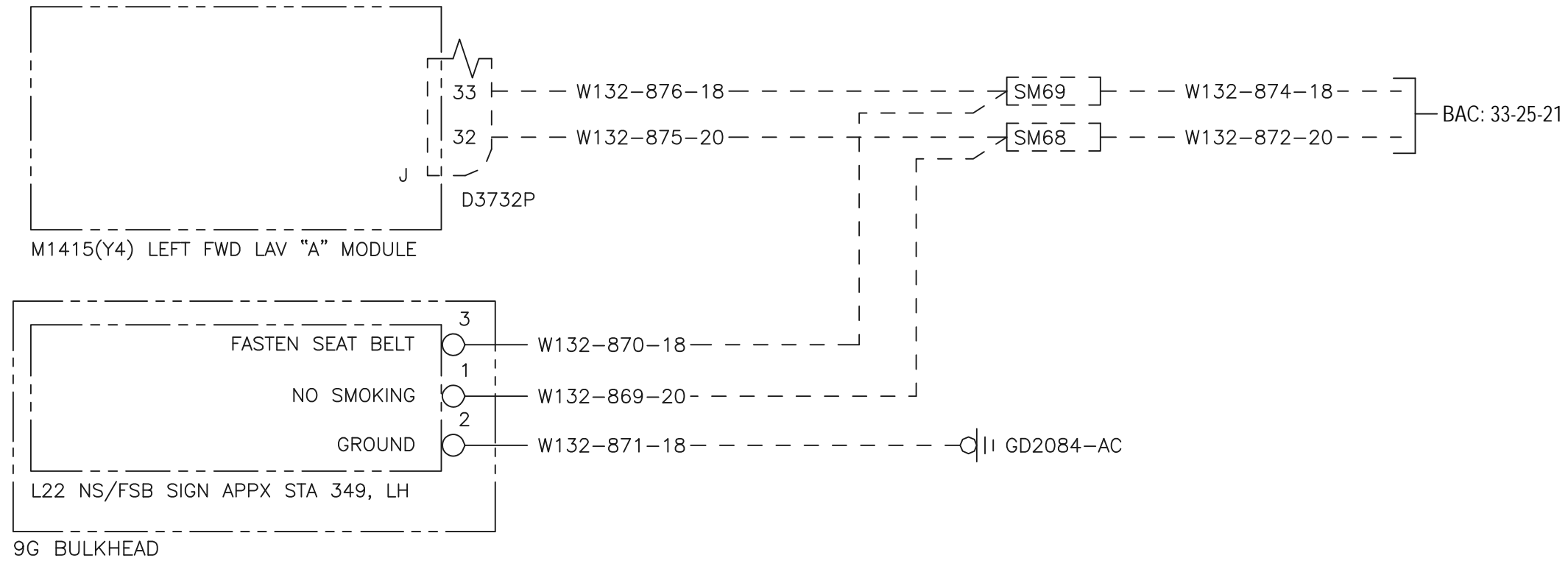

33-25-21-P3

**EFFECTIVITY:**  
SEE T.O.C.

**PASSENGER SIGNS –  
LEFT SIDE FWD**

DRAWING NO.: 0340-24-0001C  
PAGE DATE: MAY 19, 2010  
DCN: 8  
CHANGE: 24

**33-25-21**  
PAGE 3

**33-25-21**  
PAGE 3

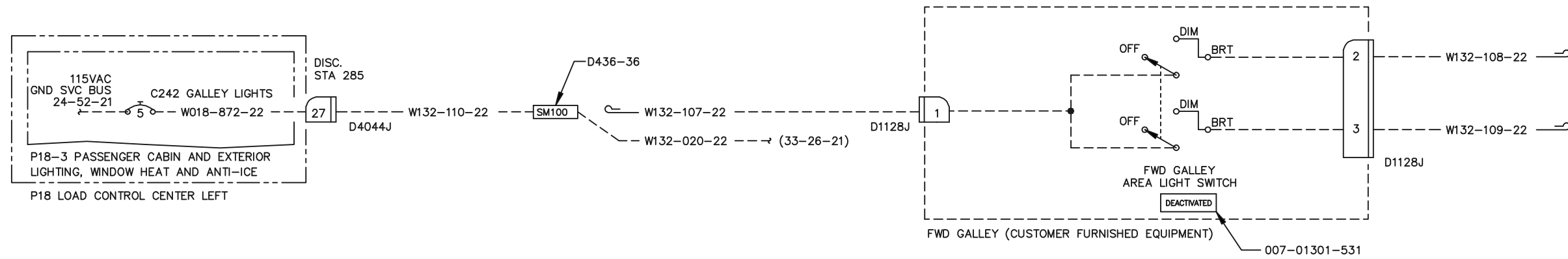

33-27-00-P1

EFFECTIVITY:  
SEE T.O.C.

FORWARD GALLEY LIGHTING

DRAWING NO.: 0340-33-0010  
PAGE DATE: MAY 19, 2010  
DCN:  
CHANGE: 24

33-27-00  
PAGE 1

33-27-00  
PAGE 1

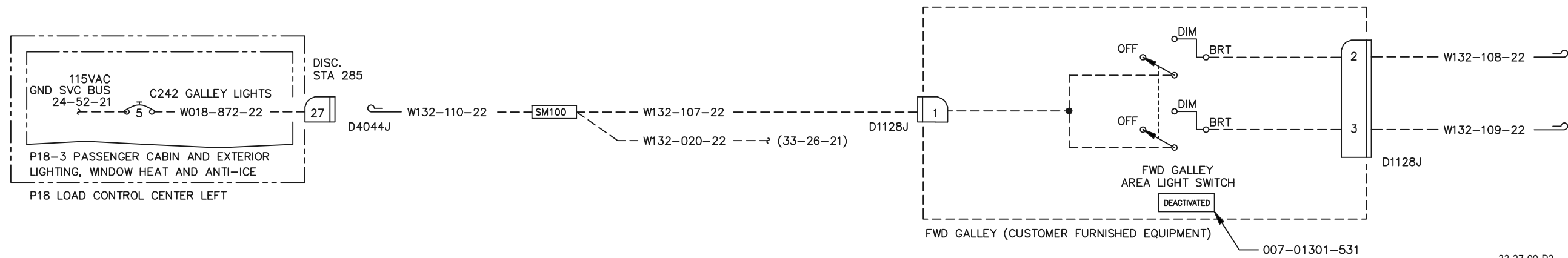

33-27-00-P2

EFFECTIVITY:  
SEE T.O.C.

FORWARD GALLEY LIGHTING

DRAWING NO.: 0340-33-0010  
PAGE DATE: MAY 19, 2010  
DCN:  
CHANGE: 24

33-27-00  
PAGE 2

33-27-00  
PAGE 2

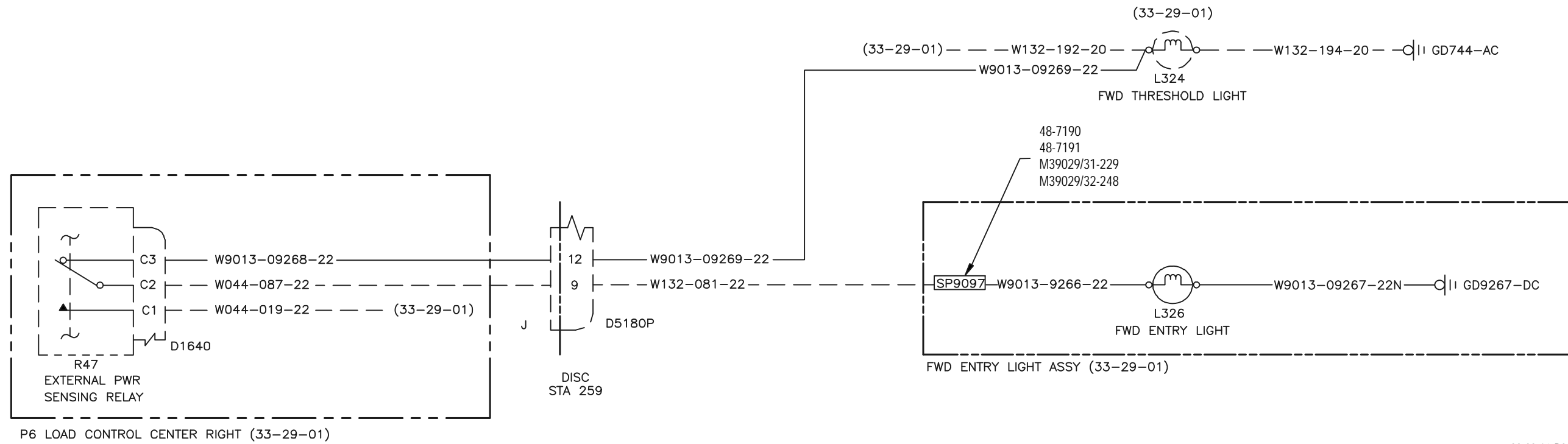

33-29-01-P2

EFFECTIVITY:  
SEE T.O.C.

FORWARD VESTIBULE LIGHTING

DRAWING NO.: 0340-33-0005A  
PAGE DATE: MAY 19, 2010  
DCN: 3  
CHANGE: 24

33-29-01  
PAGE 2

33-29-01  
PAGE 2

**B737 WIRING DIAGRAM MANUAL SUPPLEMENT**

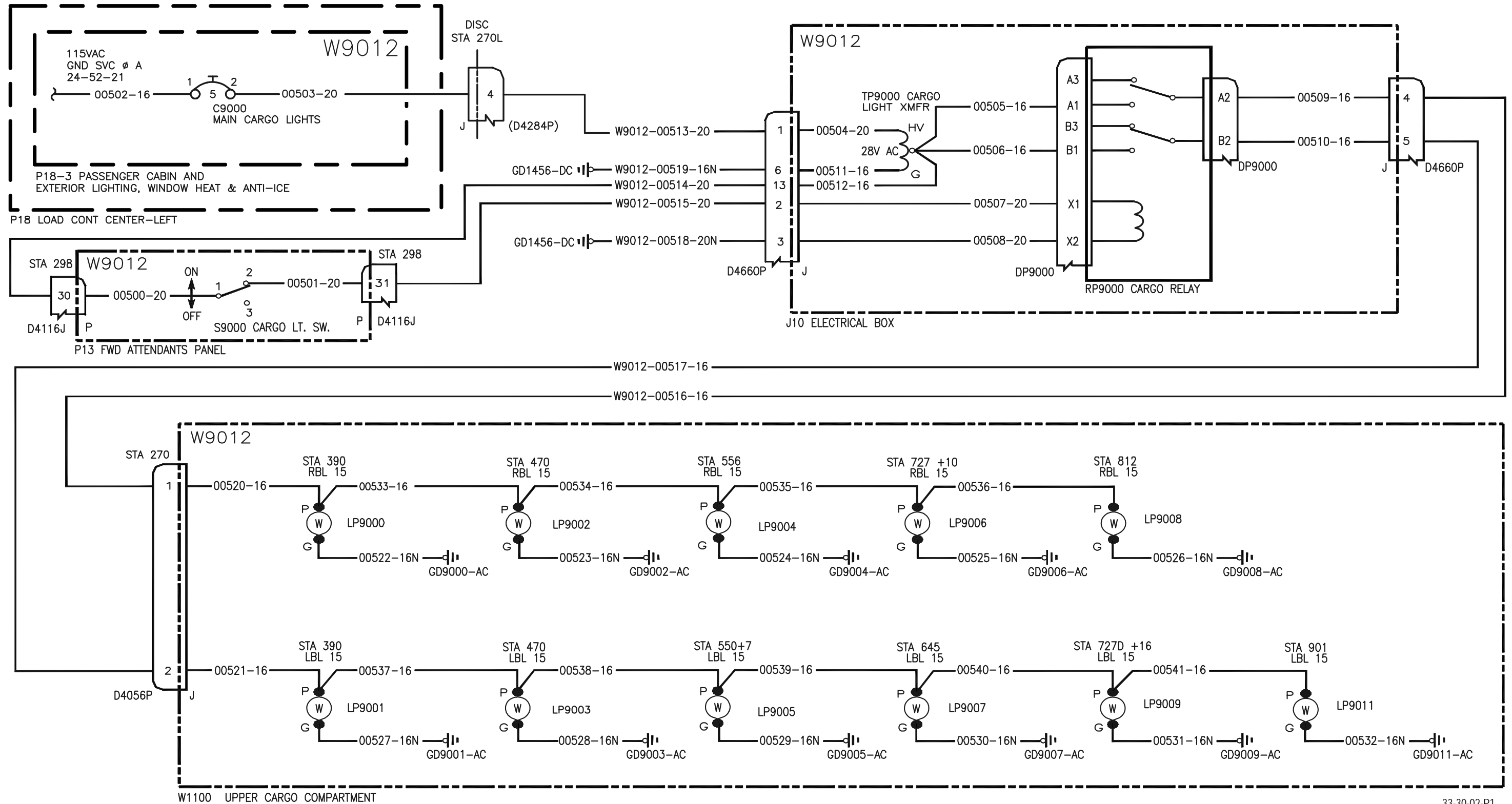

33-30-02-P1

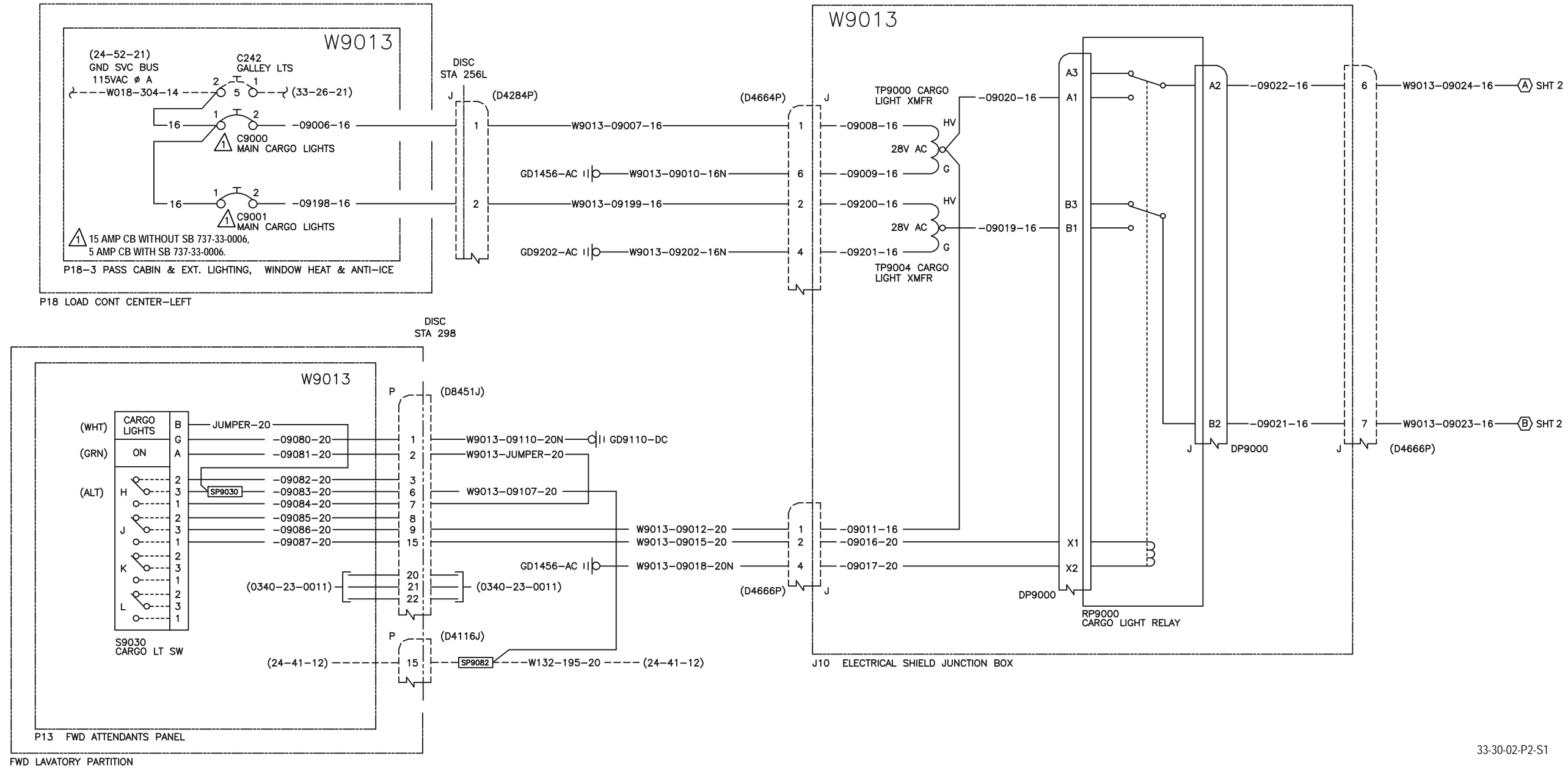

33-30-02-P2-S1

EFFECTIVITY:  
SEE T.O.C.

MAIN CARGO COMPARTMENT  
LIGHTING

DRAWING NO.: 0340-33-0006B  
PAGE DATE: MAY 19, 2010  
DCN: 1  
CHANGE: 24

33-30-02  
PAGE 2  
SHEET 1

33-30-02  
PAGE 2  
SHEET 1

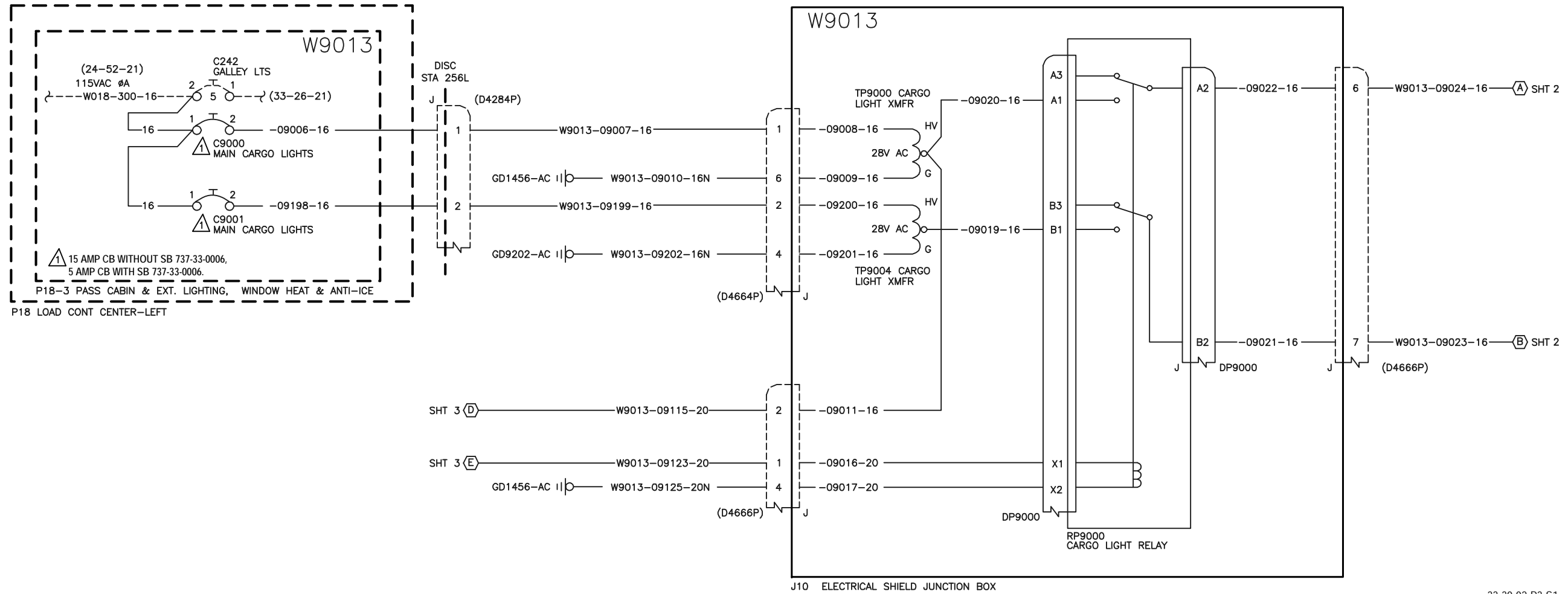

33-30-02-P3-S1

EFFECTIVITY:  
SEE T.O.C.

MAIN CARGO COMPARTMENT  
LIGHTING

DRAWING NO.: 0340-33-0007B  
PAGE DATE: MAY 19, 2010  
DCN: 1  
CHANGE: 24

33-30-02  
PAGE 3  
SHEET 1

33-30-02  
PAGE 3  
SHEET 1

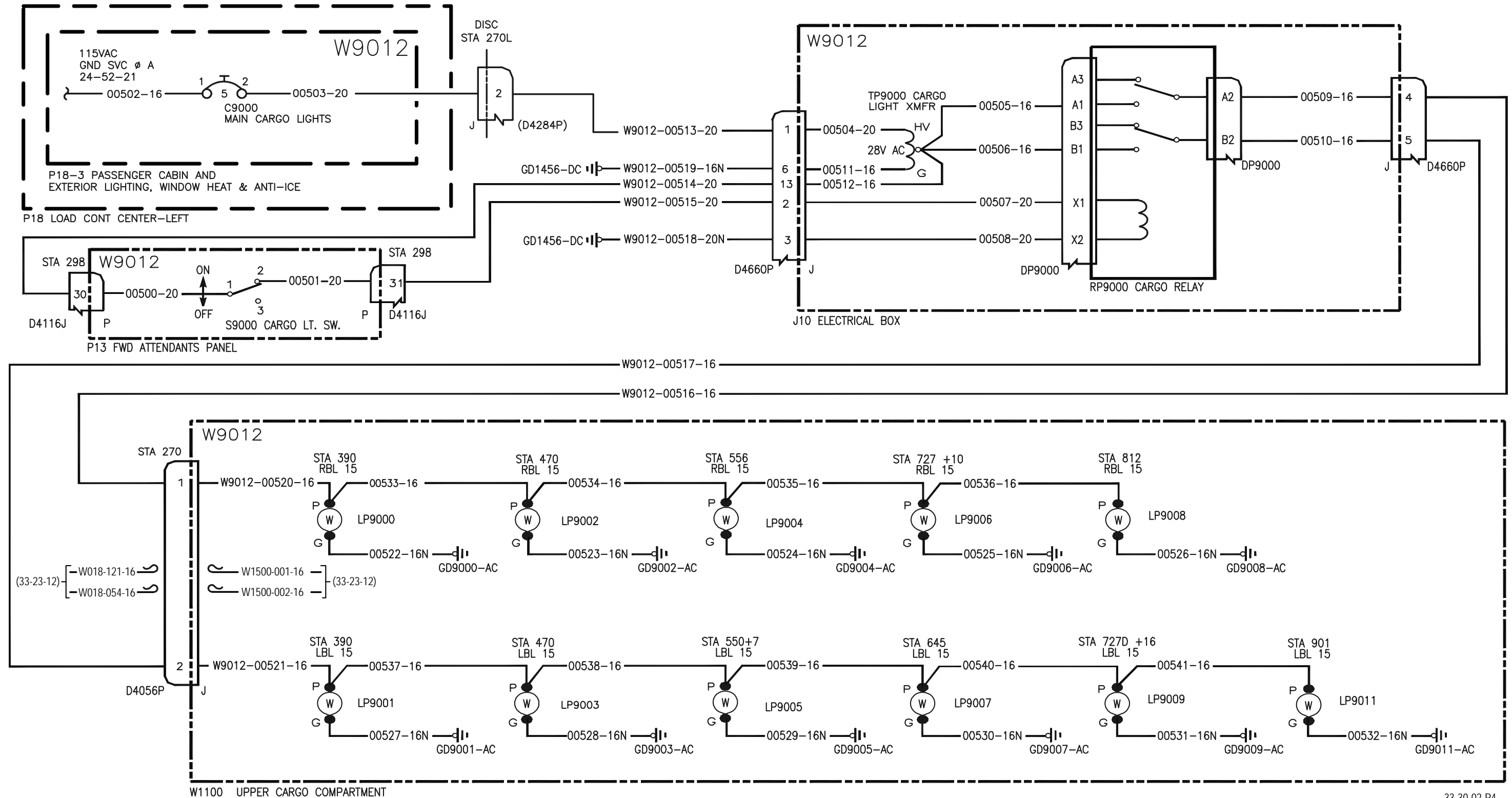

33-30-02-P4

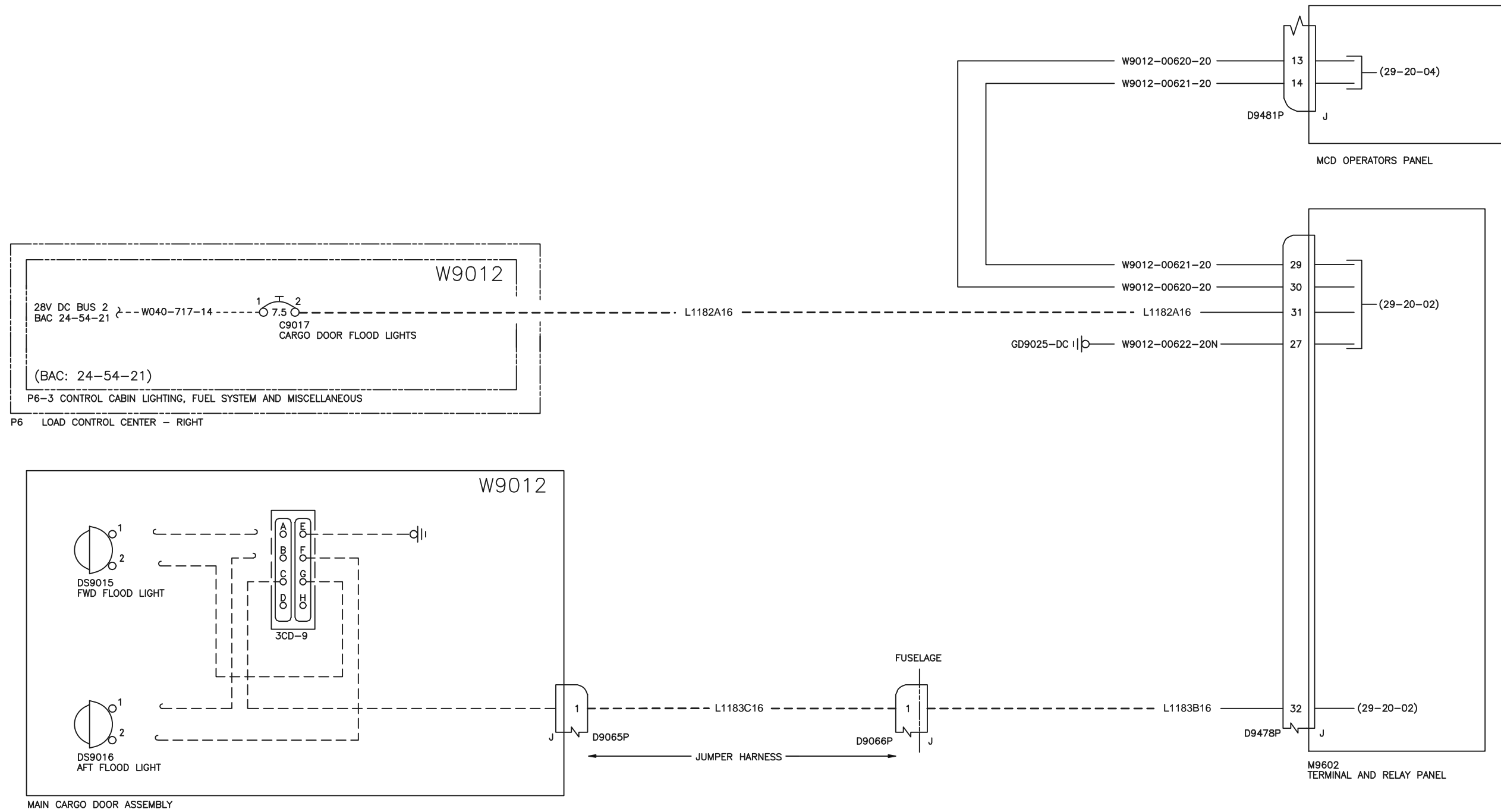

33-36-02-P2

EFFECTIVITY:  
SEE T.O.C.

CARGO DOOR LIGHTING SYSTEM

DRAWING NO.: 0301-24-0048A  
PAGE DATE: JUNE 18, 2010  
DCN: 1  
CHANGE: 25

33-36-02  
PAGE 2

33-36-02  
PAGE 2

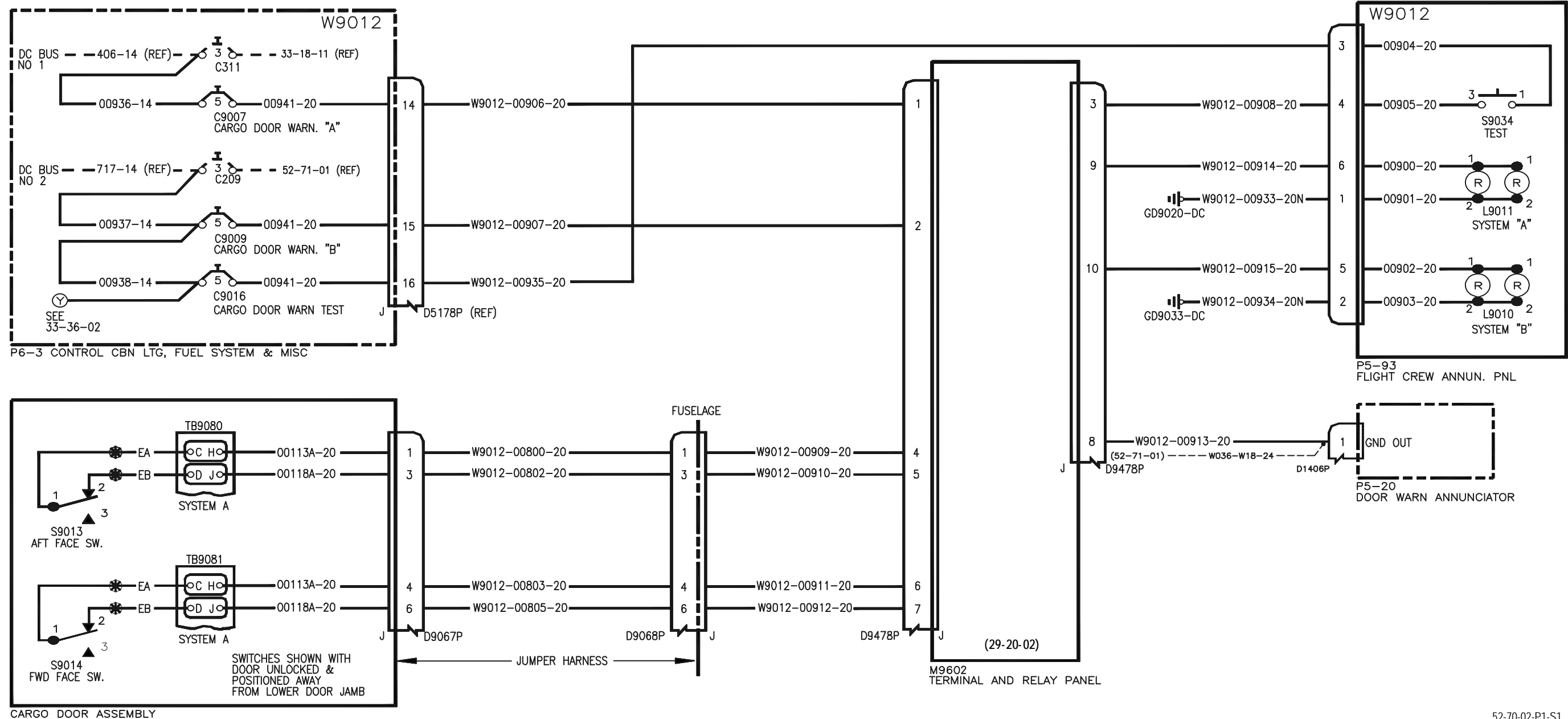

52-70-02-P1-S1

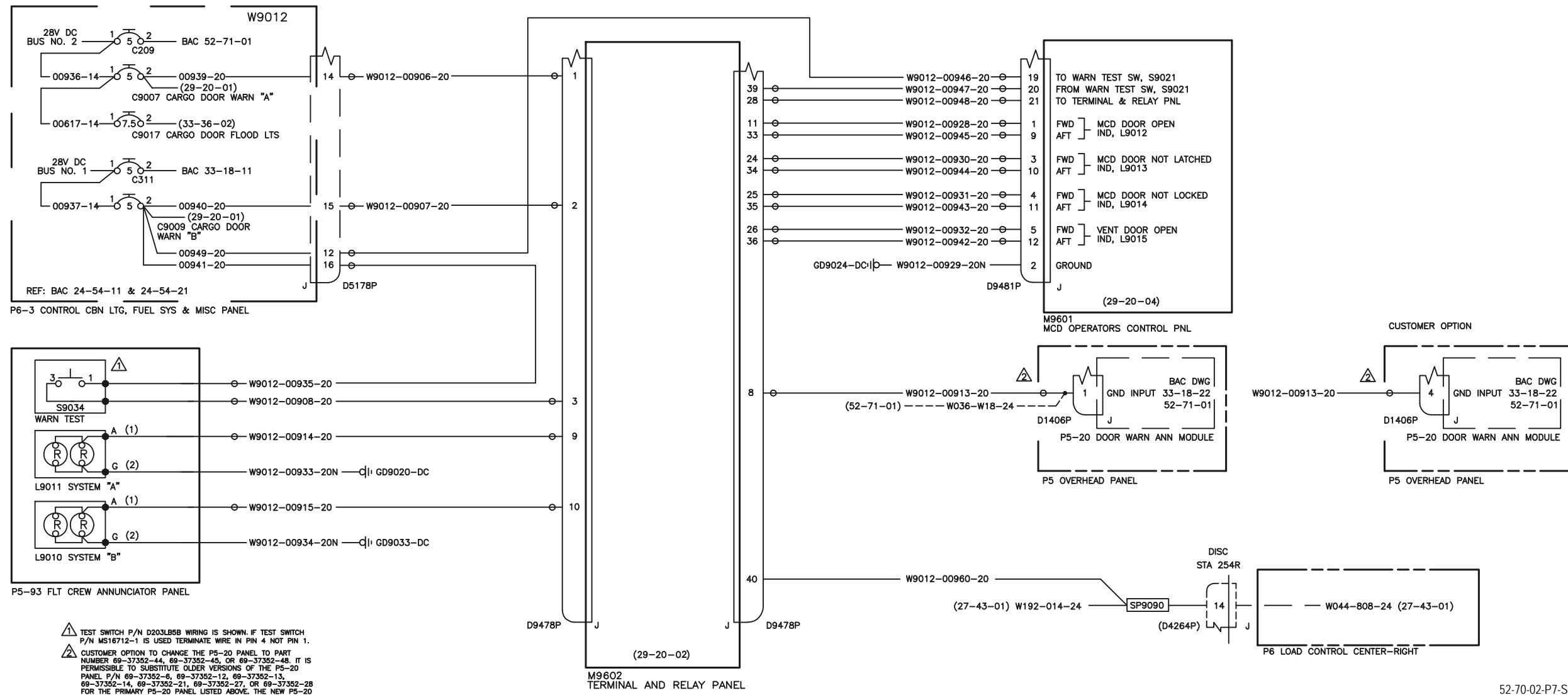

52-70-02-P7-S1

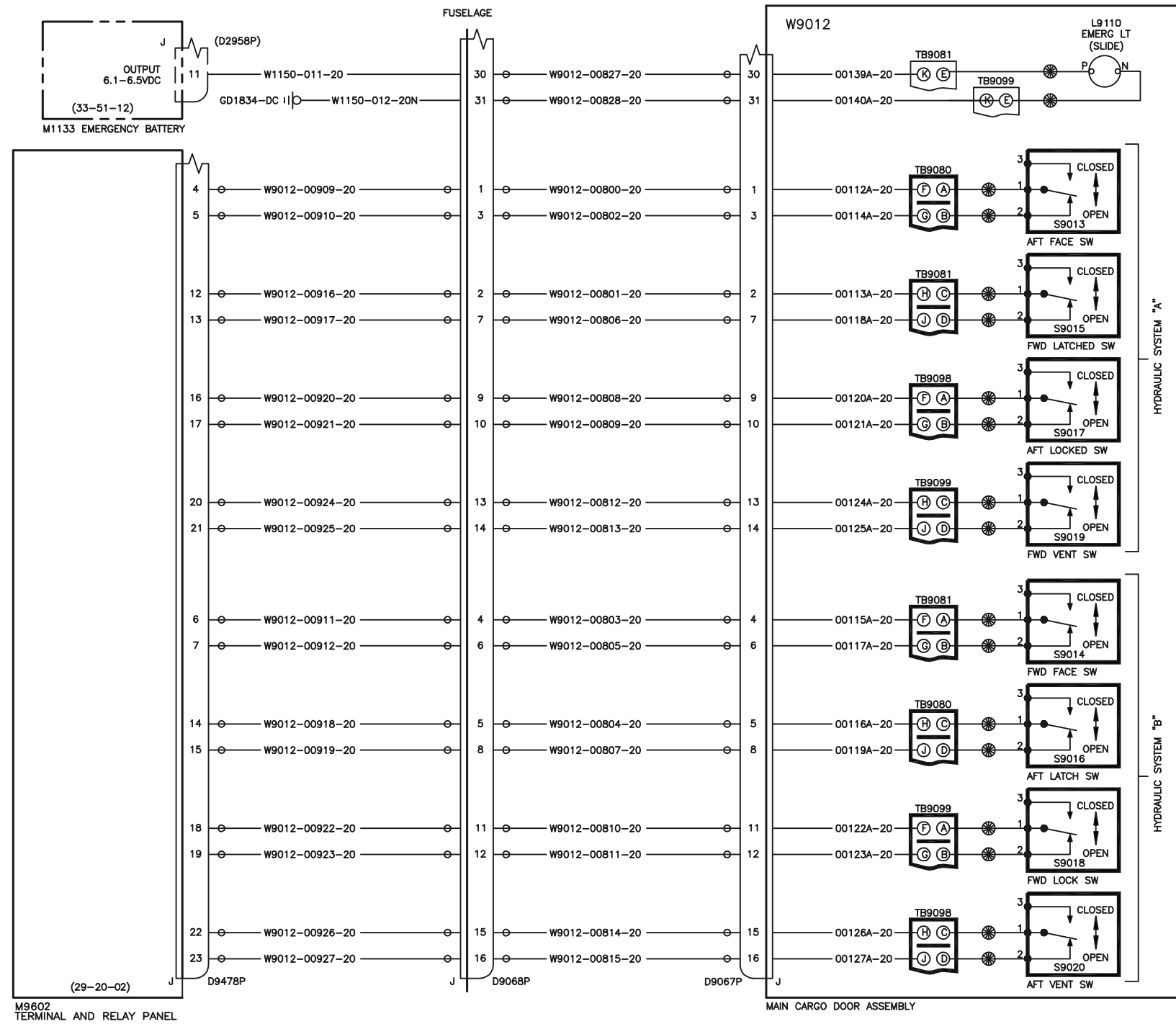

52-70-02-P7-S2

EFFECTIVITY:  
SEE T.O.C.

**CARGO DOOR ANNUNCIATOR  
SYSTEM**

DRAWING NO.: 0301-24-0050D  
PAGE DATE: JUNE 18, 2010  
DCN: 1  
CHANGE: 25

**52-70-02**  
PAGE 7  
SHEET 2

**52-70-02**  
PAGE 7  
SHEET 2

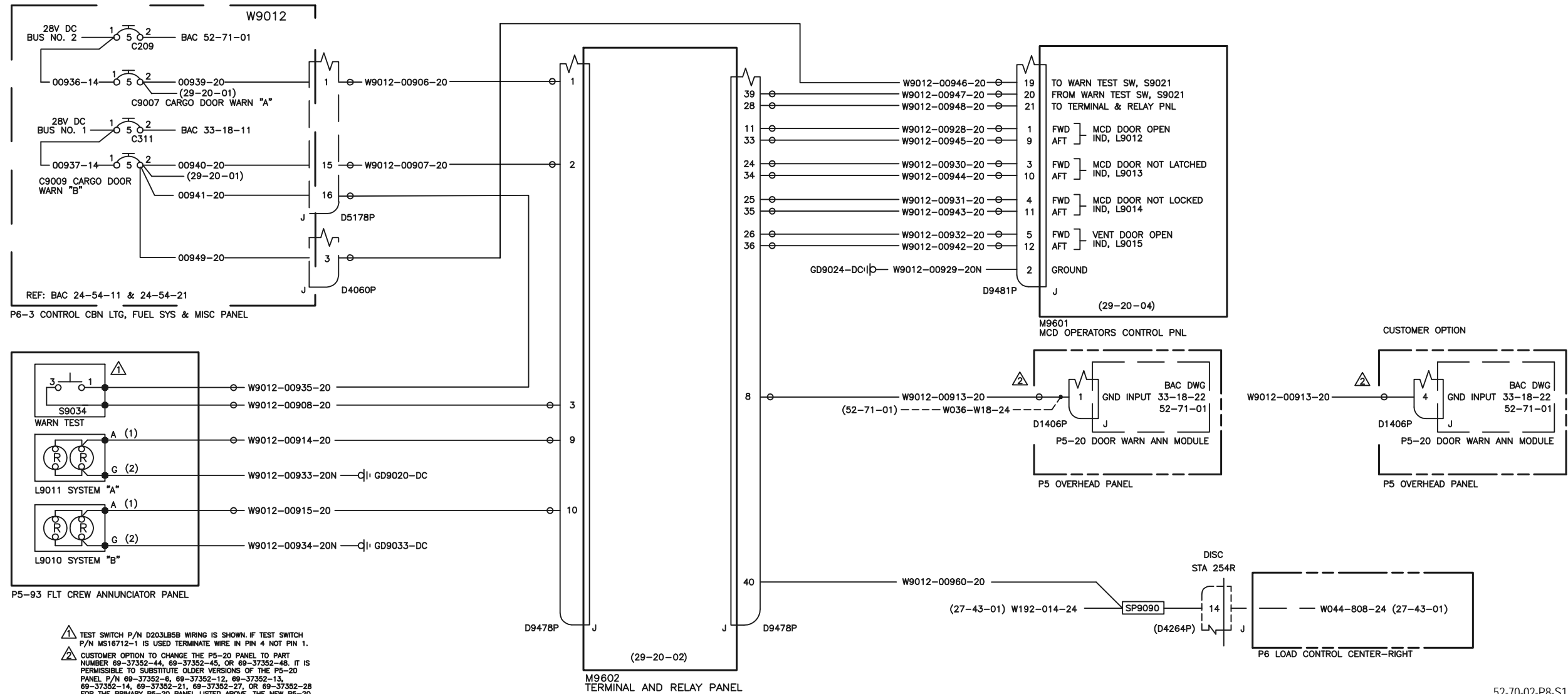

52-70-02-P8-S1

EFFECTIVITY:  
SEE T.O.C.

CARGO DOOR ANNUNCIATOR  
SYSTEM

DRAWING NO.: 0301-24-0050D  
PAGE DATE: JUNE 18, 2010  
DCN: 1  
CHANGE: 25

52-70-02  
PAGE 8  
SHEET 1

52-70-02  
PAGE 8  
SHEET 1

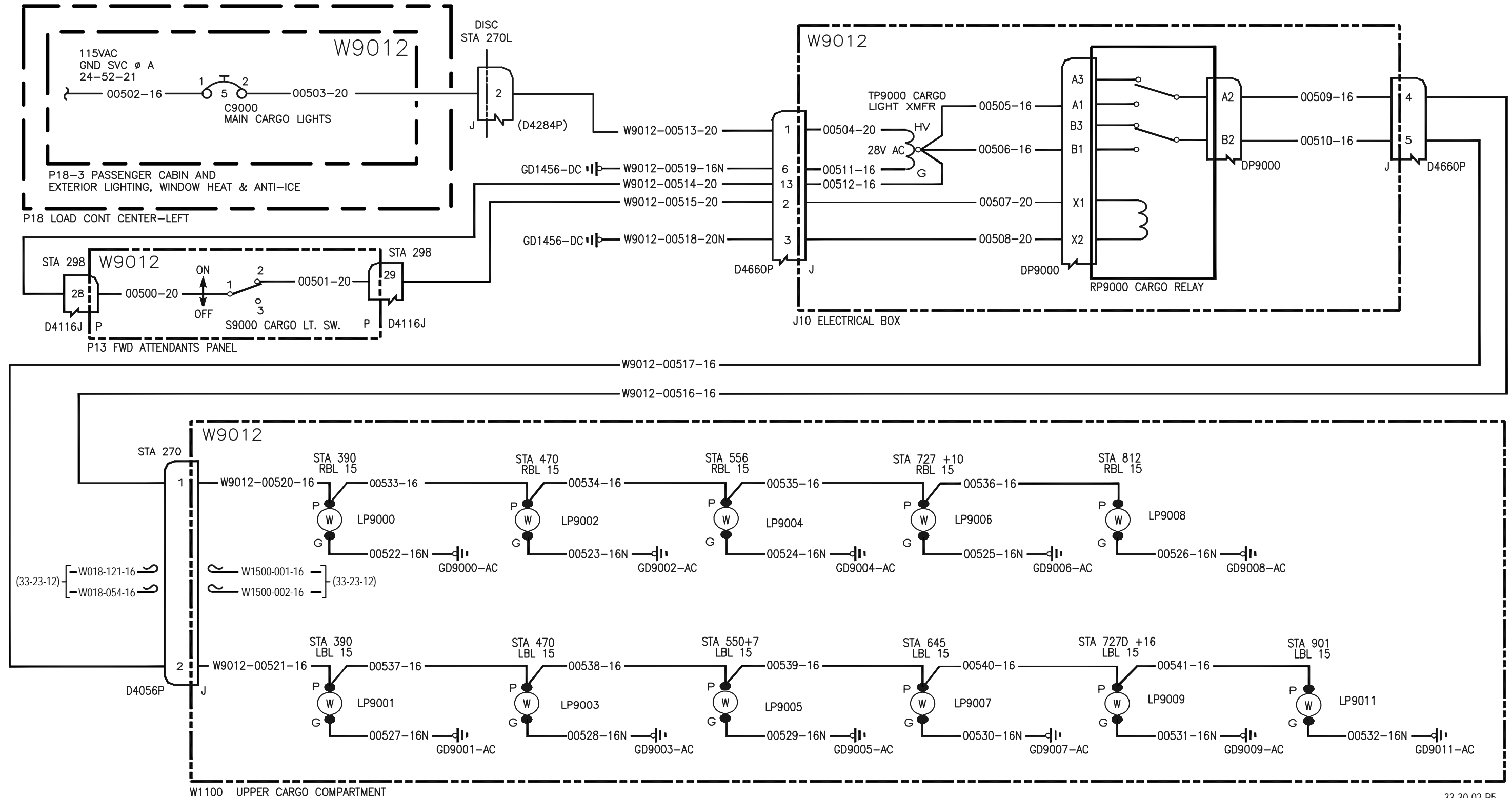

33-30-02-P5